

## BIM USER MANUAL

### **Safety warnings and recommendations**

Do not eat BIM. Before using BIM, make sure to read all the instructions below, and this User Manual. BIM has some openings on its enclosure and 4 adhesive feet for cooling purpose. To ensure sufficient cooling, do not obstruct the openings and/or remove the adhesive feet. BIM should be connected to the included AC adapter or a power supply of the type described in this manual. Do not place things on the top of the AC adapter which could prevent normal cooling. If your BIM is unused for a long period of time, disconnect the AC adapter from the outlet. BIM, in combination with an external amplification system or headphones, may generate a high sound level, which could potentially damage your ears. Do not operate BIM for a long period of time at a high volume level. It's safer to keep reasonable levels and start with low volume. Do not expose BIM and its AC adapter to rain, moisture, dust, sand or dirt. Do not pour liquids into BIM. Never use or store BIM near water, for example sea, swimming pool, bathtub, kitchen or bathroom sink. BIM should be located away from high temperatures (> 35 degrees C), for example direct sunlight in an enclosed vehicle, radiators, heat registers, stoves or other heat sources. Only clean BIM with a soft, dry cloth. Do not apply any liquids or alcohol. Do not apply excessive vibration forces to BIM, do not drop it and always transport it in its original packaging or in shock-absorbing material. Never climb on top of, nor place heavy objects on BIM. Some parts of BIM are fragile (such as the housing and some electronic components), so dropping it might damage your BIM. Repair work resulting from dropped BIM is not covered by the normal warranty of the product. Do not leave small children alone with BIM, and do not let them use

BIM unless they are capable of following all the rules for the safe operation of BIM. Do not open (or modify in any way) BIM or its AC adapter. There are no user-serviceable parts inside. Refer all servicing to qualified personnel only. If you think your BIM needs repair, you can send us an e-mail at : [support@otomachines.com](mailto:support@otomachines.com).

### **Warranty**

BIM is sold with one year full warranty. This warranty covers all malfunctions that may occur from normal use, and does not cover damage due to abuse, faulty connections or operation under other than specified conditions. Warranty is void when serial number is unreadable, when the device is repaired by unauthorized persons, opened, or tampered with in any way, or if the product was not sold to the end user through an authorized dealer or the OTO Machines website. This warranty is limited to replacement or repair of the product. The unit can only be returned for repair after agreement from OTO Machines. Customer covers shipping cost of faulty BIM to OTO Machines and OTO Machines covers shipping cost back to customer.

### **Disposal**

The trash can symbol indicates that your product must be disposed of properly according to local laws and regulations.

### **Warning on epilepsy**

A very small percentage of individuals may experience epileptic seizures or blackouts when exposed to certain light patterns or flashing lights. If you have an epileptic condition or have had seizures of any kind, consult your physician before using BIM.

## TABLE OF CONTENTS

<b>Presentation - Features</b>	<b>Page 03</b>
<b>Front panel - Rear panel</b>	<b>Page 04</b>
<b>Setup examples</b>	<b>Page 06</b>
<b>Parameters</b>	<b>Page 07</b>
<b>Division - Range</b>	<b>Page 08</b>
<b>FX Type - In Gain</b>	<b>Page 09</b>
<b>Filters - Feedback</b>	<b>Page 10</b>
<b>Offset - LFO</b>	<b>Page 11</b>
<b>Active mode - Tap Tempo destination</b>	<b>Page 12</b>
<b>Display mode - Local mode</b>	<b>Page 13</b>
<b>Feedback limiter - LFO Divisions - Freeze mode</b>	<b>Page 14</b>
<b>Presets - Recall - Save</b>	<b>Page 15</b>
<b>Factory Presets</b>	<b>Page 16</b>
<b>Memory protect</b>	<b>Page 17</b>
<b>MIDI</b>	<b>Page 17</b>
<b>MIDI CC list</b>	<b>Page 20</b>
<b>Specifications - Reset</b>	<b>Page 21</b>
<b>Shortcuts summary</b>	<b>Page 22</b>

## PRESENTATION

Congratulations and thank you for purchasing BIM!

BIM is a 12-bit stereo delay unit inspired by some studio delay processors built in the early 80s.

These monophonic processors have been renowned for the quality and musicality of their sound. The processing was mainly analog (compressors, limiters, low-pass filters, feedback path,...), and the signal was converted to digital just for the delay section, using 12-bit AD/DA converters and some RAM memory chips.

The advantage of this technology is particularly obvious when the sound is feedbacked many times through the whole analog and 12-bit circuitry. You'll hear a sweet degradation and dark damping that the 100% digital delay boxes can't offer.

When we designed BIM, we wanted to create a unique, modern and versatile effects processor based on this 80s technology. We managed to mix the fabulous sound of an old 12-bit digital delay with modern features such as stereo processing, extra FXs, many user presets, MIDI control, tap tempo, compact size... therefore BIM is the best of both worlds!

BIM is the perfect companion for the musician, producer, sound engineer or live performer who is looking for a unique, warm and musical delay processor.

## FEATURES

- Up to 3276 milliseconds in stereo
- True 12-bit converters, analog limiter, compressors, filters and feedback path
- 4 delay types : Normal, Dual Head, Disto, Lo-Fi
- Delay high-pass filter : 20Hz, 100Hz, 250Hz or 500Hz
- Delay low-pass filter : 16kHz, 8kHz, 4kHz or 2kHz
- Feedback filters : flat, lo cut, hi cut or both
- LFO with 4 waveforms and 4 rate ranges (from 0.025 Hz to 147 Hz)
- Tap Tempo with sub-division settings
- Freeze switch with normal or reverse play
- Delay input gain from 0 to +15dB
- 36 user presets
- MIDI input : BIM responds to MIDI Clock, CC and Pgm Change
- 3 bypass modes : Relay, Spillover and Aux
- Nice and simple user interface via 16 white LEDs
- Rugged steel enclosure
- Neutrik® jack connectors
- Power supply included

## FRONT PANEL & REAR PANEL

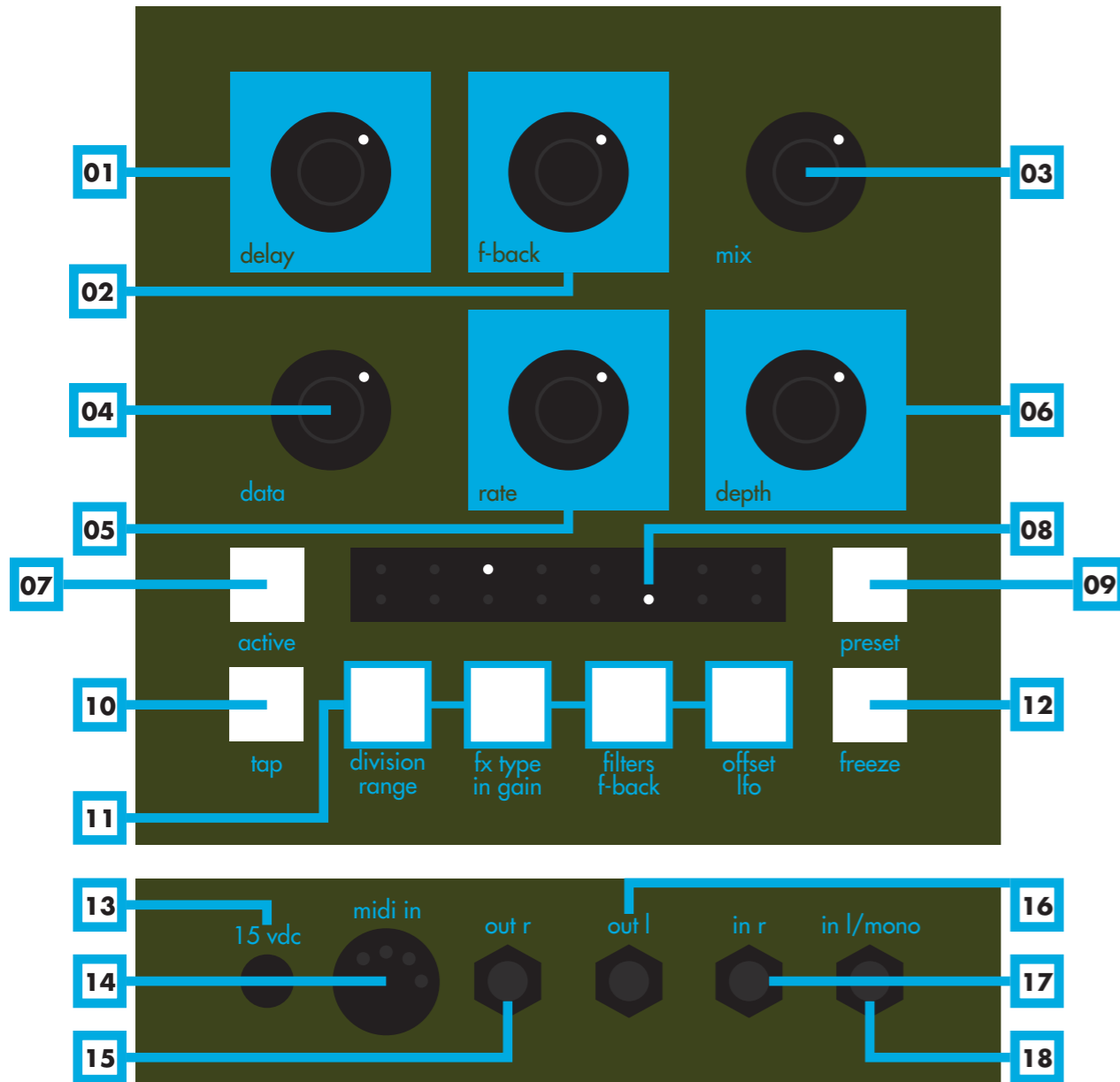

- 01 - DELAY.** Sets the delay time
- 02 - F-BACK.** Sets the feedback amount
- 03 - MIX.** Mix between the dry and wet sound
- 04 - DATA.** Sets the selected parameter (cf p.7)
- 05 - RATE.** Sets the speed of the LFO for delay time modulation
- 06 - DEPTH.** Sets the amount of the LFO
- 07 - ACTIVE.** Turns the effect on or off (when it's off, the delay is bypassed)
- 08 - LEDS.** Display the parameters, presets, midi settings and other infos
- 09 - PRESET.** Save and Recall presets
- 10 - TAP.** Tap tempo. Flashes in rhythm with the tempo
- 11 - FUNCTION KEYS.** Give access to the parameters (cf p.8 to 11)
- 12 - FREEZE.** Reads the current delay memory in loop
  
- 13 - POWER SUPPLY INPUT.** 15 Volts DC 0.5 Amps, center positive
- 14 - MIDI IN.** Midi input
- 15 - OUT R.** Right output. Unbalanced 1/4" jack
- 16 - OUT L.** Left output. Unbalanced 1/4" jack
- 17 - IN R.** Right input. Unbalanced 1/4" jack
- 18 - IN L/MONO.** Left or mono input. Unbalanced 1/4" jack

## SETUP EXAMPLES

### 1. Instrument

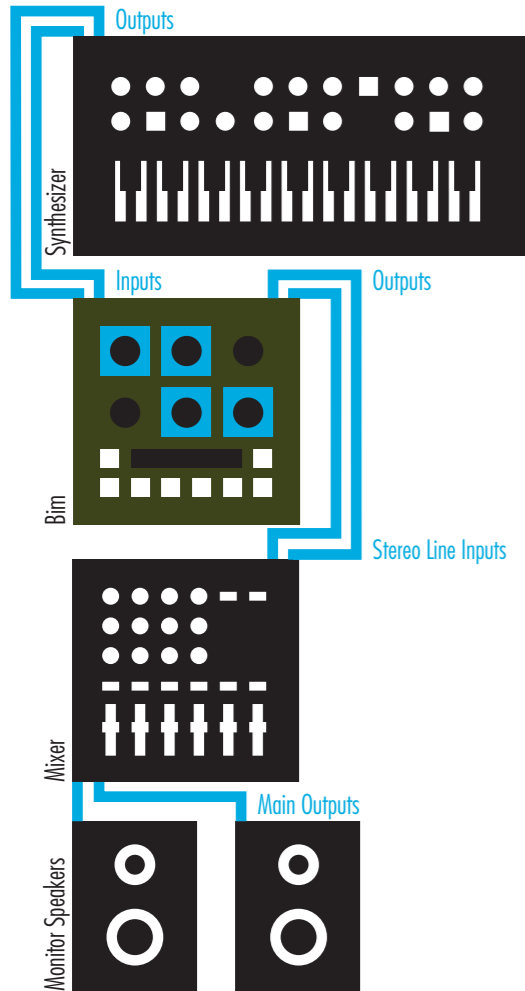

### 2. Auxiliary

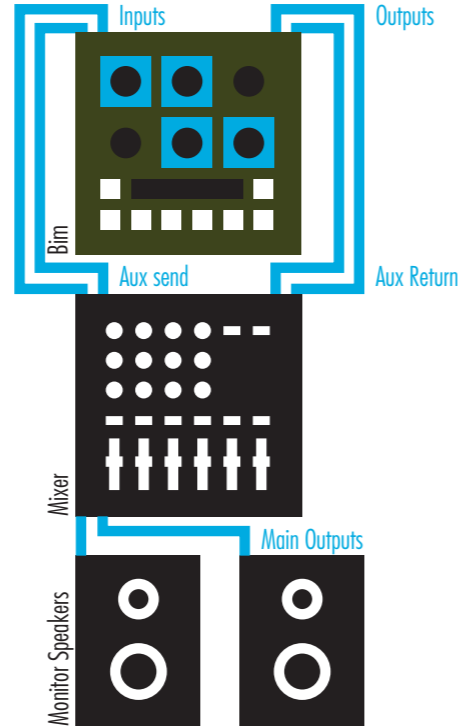

NOTE : turn the MIX pot to its maximum position (right) or set BIM in « Aux mode » (cf. page 12)

## PARAMETERS

BIM has 10 parameters spread out over 4 function keys : Division/Range, FX Type/In Gain, Filters/F-Back and Offset/LFO. The first 2 function keys give you access to 2 parameters, and the 2 others to 3 parameters.

Each press on the corresponding function key will cycle through each available parameter. This selected parameter will flash and can then be modified with the DATA pot.

To exit parameter selection press the function key until the LEDs go off.

### Function Key Overview

**1. Division/Range.** Division sets the musical value of the delay. Range sets the global delay memory size. These two values are interlinked.

**2. FX Type/In Gain.** FX Type gives you access to 4 effects. In Gain sets the input gain of the delay.

**3. Filters/F-Back.** This function key has 3 parameters : HPF, LPF and Feedback Filters. HPF and LPF are displayed on the upper line and are applied to the output of the delay. Feedback Filters are displayed on the lower line.

**4. Offset/LFO.** This function key has 3 parameters : Offset, LFO wave and LFO range. Offset is displayed on the upper line and sets the time difference between left and right delays. LFO wave and LFO range are displayed on the lower line. LFO wave has 4 waveforms. LFO range switches between 4 ranges of the LFO speed.

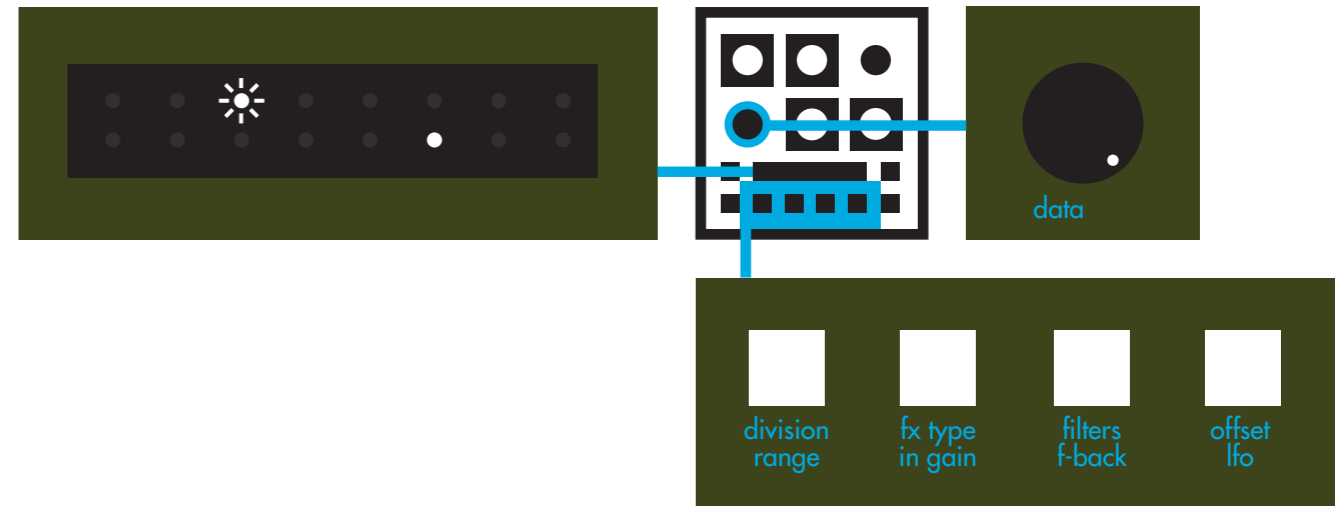

## DIVISION/RANGE

**Division.** Sets the musical division of the delay as related to the tempo.

NOTE : When you tap a new tempo, the quarter note is automatically selected.

**Range.** Selects the range of memory used for the delay, expressed in milliseconds. The min and max value displayed here correspond to the min and max positions of the DELAY pot. This parameter is associated with the DELAY pot to set the tempo manually, but it can also be used to divide or multiply the TAP or MIDI tempo by a factor of 2, 4, 8....

NOTE : When you enter a new tempo tap or midi, the RANGE value may automatically change. You cannot modify the RANGE parameter when BIM is synced to MIDI Beat Clock.

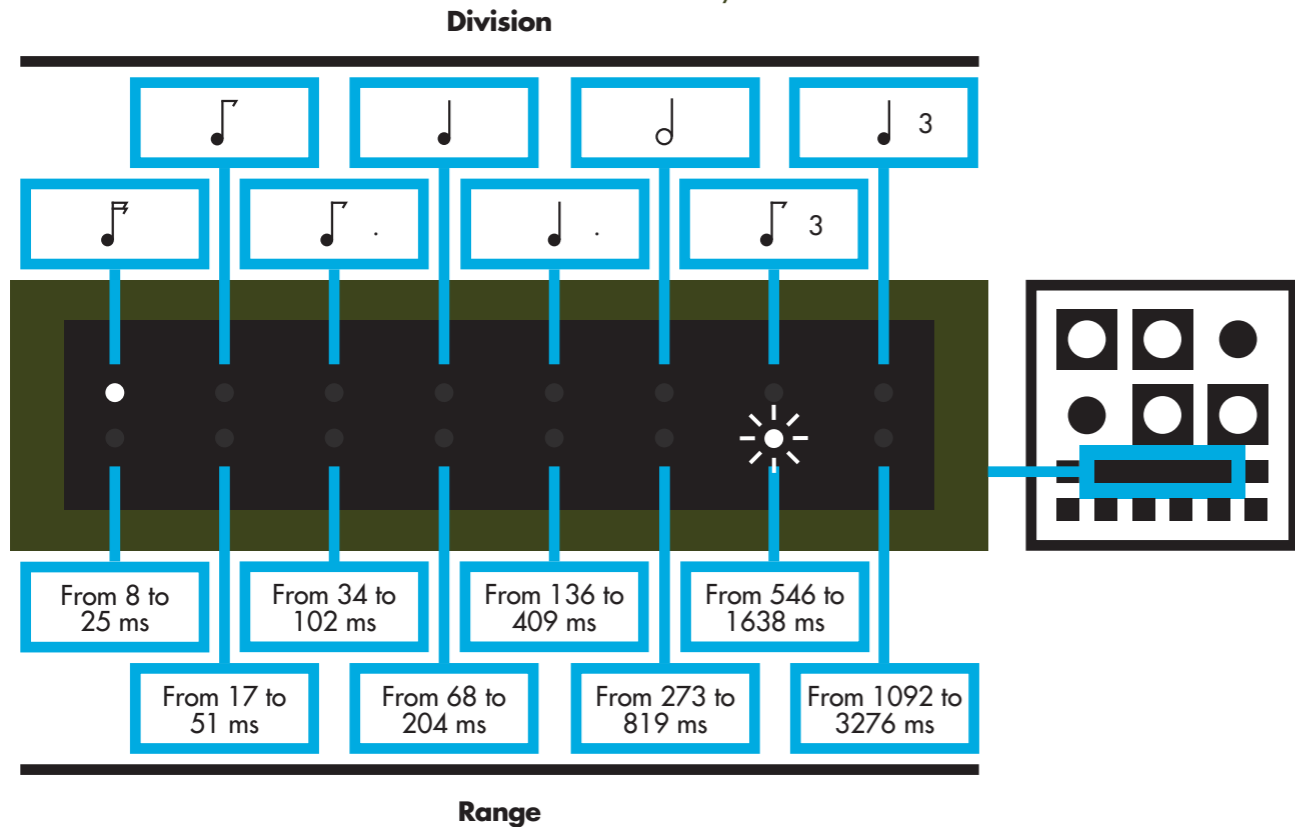

## FX TYPE/IN GAIN

**FX Type.** Selects the delay type.

**In Gain.** Sets the input gain of the delay from 0 dB to +15 dB. Due to the built-in compressor, increasing gain can add a nice character to the delayed sound.

Normal	Standard Delay
Dual	Uses 2 different read positions for great stereo effects
Disto	Adds soft distortion to the delay
Lo-Fi	Adds asymmetrical distortion and low-pass filtering to the delay

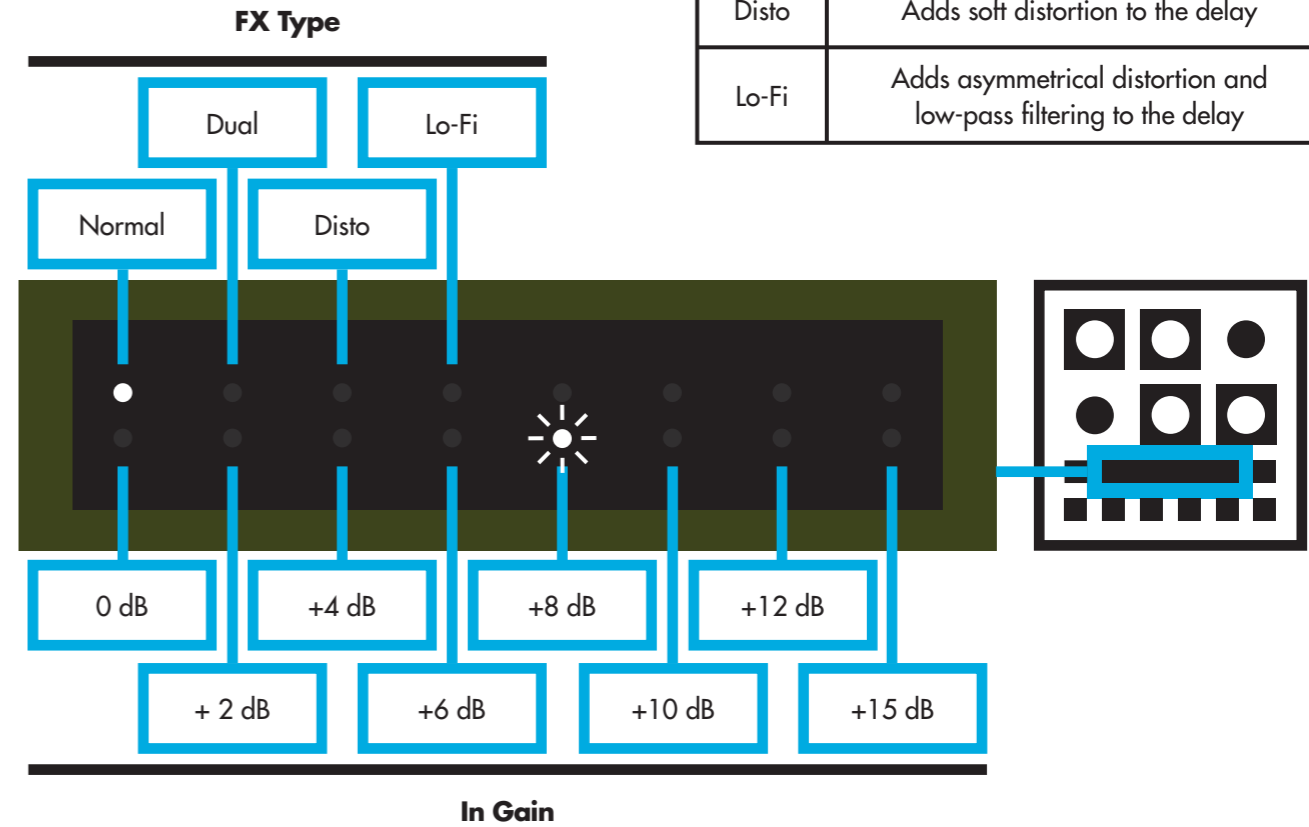

## FILTERS/F-BACK

**HPF.** Selects the cutoff frequency of the delay high-pass filter.  
**LPF.** Selects the cutoff frequency of the delay low-pass filter.

**FB Filters.** Selects which kind of filters are inserted in the Feedback path (in addition to the delay filters).

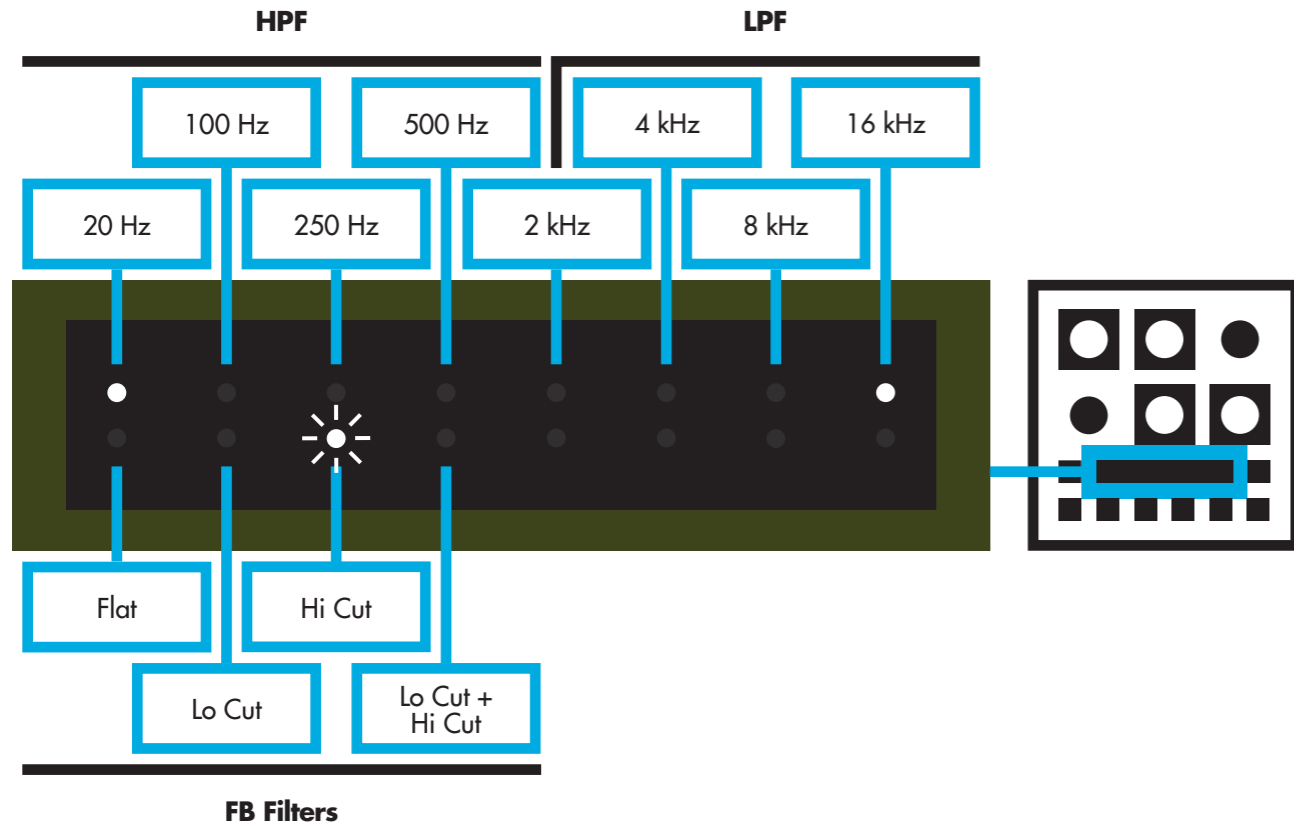

## OFFSET/LFO

**Offset.** Sets the interval between the right and left delay time. The right delay is fixed and the offset is expressed as a percentage, so that «50%» means that the left delay is half the value of the right delay.

**LFO Waveform.** Selects the waveform of the LFO.  
**LFO Range.** Selects the LFO frequency range of the RATE pot.

NOTE : Offset is automatically set to 0% when the right output is unplugged (mono out).

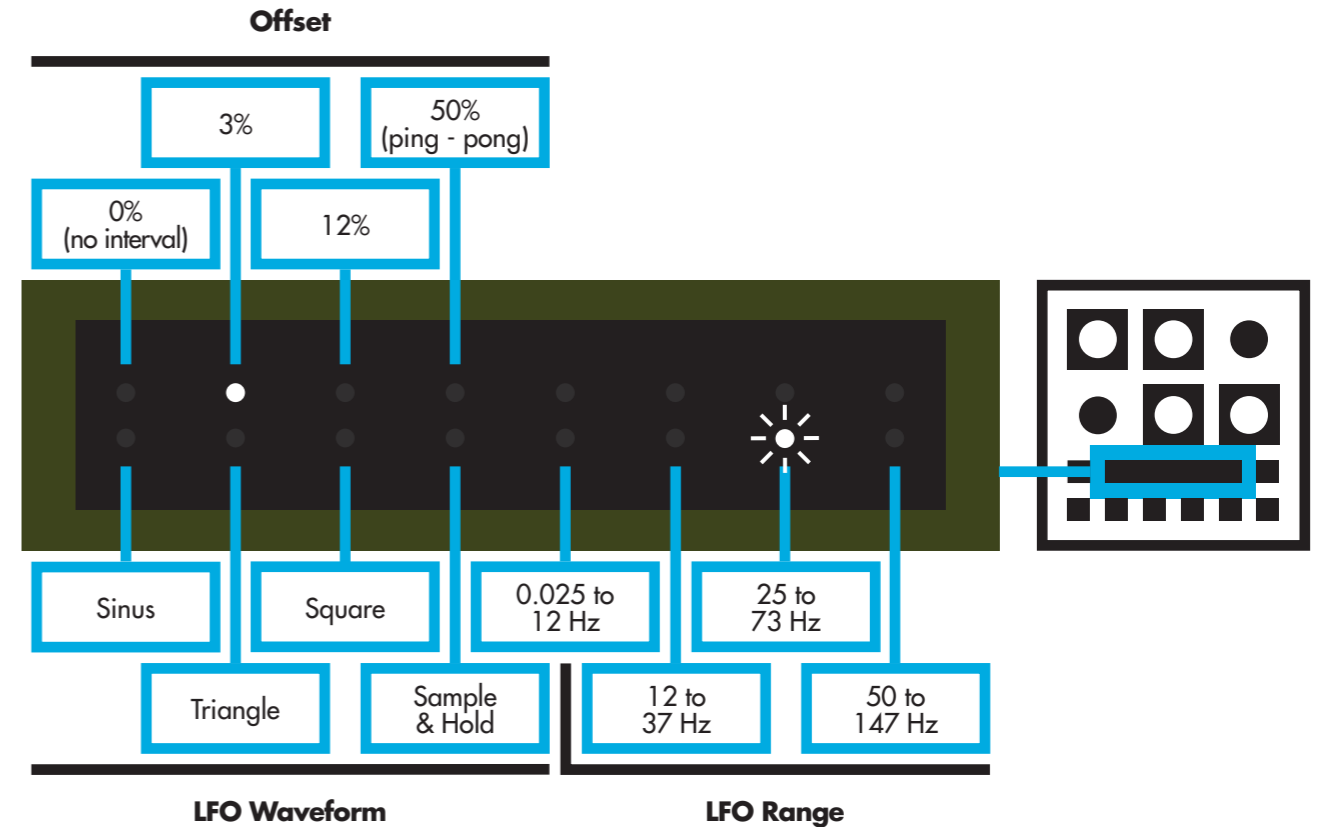

## ACTIVE MODE

The ACTIVE switch has three Bypass modes : Relay, Spillover and Aux.

To change the Bypass mode, press and hold the ACTIVE switch for at least 2 seconds. The ACTIVE switch and one of the LEDs will flash to indicate the current Bypass mode :

- Led 1.** Relay. When ACTIVE switch is off, inputs are directly connected to the outputs via a relay, and the electronics are completely bypassed. The tail of the delay is muted when ACTIVE switch is off.
- Led 2.** Spillover. This is an electronic bypass, the tail of the delay is not muted when the ACTIVE switch is off.
- Led 3.** Aux. The MIX pot sets the level of the delay and the ACTIVE switch mutes the delay input when it's off.

You can change the bypass mode with the DATA pot. To exit the ACTIVE settings, wait for 10 seconds or press the ACTIVE switch.

NOTE : When BIM is switched off, inputs are directly connected to the outputs via the relay.

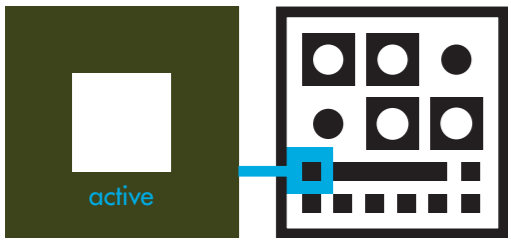

## TAP TEMPO DESTINATION

The TAP tempo switch can be assigned to either the Delay Time, the LFO Rate or both.

To change the TAP Tempo mode, press and hold the TAP switch for at least 2 seconds. The TAP switch and one of the following LEDs will flash to indicate the current TAP Tempo destination :

- Led 1.** Tap tempo is only assigned to Delay Time.
- Led 2.** Tap tempo is only assigned to LFO rate. You can change the subdivision with the LFO Divisions setting (cf. page 14).
- Led 3.** Tap tempo is assigned to both Delay Time and LFO Rate.

You can change this destination with the DATA pot. To exit the TAP Tempo settings, wait for 10 seconds or press the TAP switch.

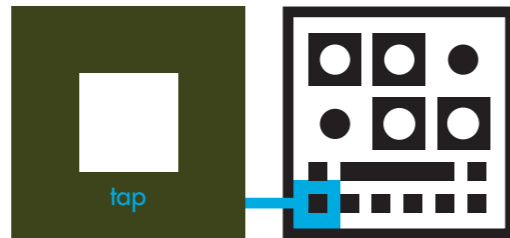

## DISPLAY MODE

When no parameter is selected, you can choose what the screen will display.

To change the Display mode, press and hold the DIVISION function key for at least 2 seconds. The DIVISION function key and one of the following LEDs will flash to indicate the current Display mode :

- Led 1.** OFF mode. The screen will display nothing.
- Led 2.** VU-METER mode. The 16 LEDs act as a VU meter and display the delay input level (the upper line for the left input, the lower line for the right input).
- Led 3.** LFO mode. The 16 LEDs will move at the LFO rate.
- Led 4.** PRESET mode. The 16 LEDs show the current preset and bank number.

You can change the Display mode with the DATA pot. To exit the Display mode settings, wait for 10 seconds or press the DIVISION function key.

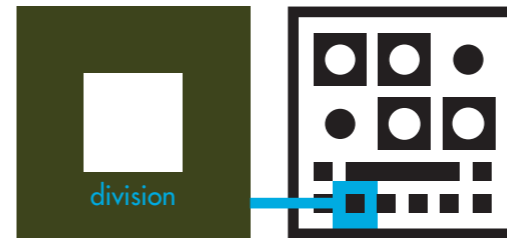

## LOCAL MODE (TEMPO & MIX)

Each Preset contains its own Tempo (Tap or Time settings) and Mix value. Sometimes it can be useful to load a preset while keeping the current Tempo and Mix settings.

To change the Local mode, press and hold the FX TYPE function key for at least 2 seconds. The FX TYPE function key and one of the following LEDs will flash to indicate the current Local mode :

- Led 1.** PRESET mode. The Tempo and Mix values are loaded from the preset.
- Led 2.** LOCAL mode. The Tempo and Mix values from the loaded preset are ignored and the current Tempo and Mix values are used.

You can change the Local mode with the DATA pot. To exit the Local mode settings, wait for 10 seconds or press the FX TYPE function key.

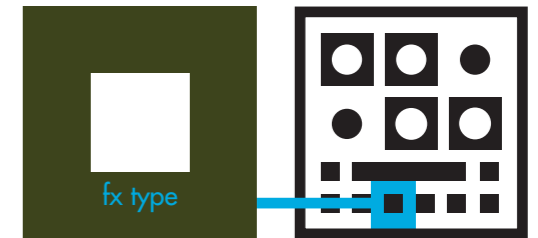



## FEEDBACK LIMITER

Because of its high dynamic circuitry, BIM automatically prevents the feedback to reach self-oscillation. You can bypass this protection, but be aware that the self-oscillation can lead to a high level when the F-BACK pot is set to its maximum position. To deactivate the Feedback limiter, press and hold the FILTERS function key for at least 2 seconds. The FILTERS function key and one of the following LEDs will flash to indicate the current Feedback mode :

**Led 1.** Feedback limiter ON.

**Led 2.** Feedback limiter OFF.

NOTE : This setting can lead to excessive feedback level when you turn the F-BACK pot to its maximum position !

You can turn the Feedback limiter on or off with the DATA pot. To exit the Feedback limiter settings, wait for 10 seconds or press the FILTERS function key.

## LFO DIVISIONS

You can set the subdivisions for the LFO Rate when TAP tempo is assigned to the LFO Rate. To change the LFO Divisions, press and hold the OFFSET function key for at least 2 seconds. The OFFSET function key and one of the following LEDs will flash to indicate the current LFO Division :

**Led 1.** Sixteenth note

**Led 2.** Eighth note

**Led 3.** Quarter note

**Led 4.** Half note

**Led 5.** Whole note

You can change the LFO Divisions with the DATA pot. To exit the LFO Divisions settings, wait for 10 seconds or press the OFFSET function key.

## FREEZE MODE

The FREEZE switch can be set to operate in either Latch or Momentary mode. To change the Freeze mode, press and hold the FREEZE and the OFFSET function keys simultaneously for at least 2 seconds. The FREEZE switch and one of the following LEDs will flash to indicate the current Freeze mode :

**Led 1.** Latch. Freeze is on when you press the FREEZE switch. Freeze turns off when you press the FREEZE switch again.

**Led 2.** Reverse Latch. Same as 1 but the Freeze is played in reverse.

**Led 3.** Momentary. Freeze is only on when you depress the FREEZE switch.

**Led 4.** Reverse Momentary. Same as 3 but the Freeze is played in reverse.

You can now change the Freeze mode with the DATA pot. To exit the Freeze mode settings, wait for 10 seconds or press the FREEZE switch.

## PRESET

BIM has 36 presets; 6 banks of 6 presets each. The upper line of LEDs (1 to 6) indicates the bank. The lower line of LEDs (9 to 14) indicates the preset.

### Recall a Preset

Press the PRESET switch. The PRESET switch lights up and one of the upper line LEDs blinks. Press one of the 6 switches (from TAP to FREEZE) to select a bank. Then one of the lower line LEDs blinks. Press one of the 6 switches (from TAP to FREEZE) to select a preset. Your preset is loaded.

### Save a preset

Press the PRESET switch for 2 seconds. The PRESET switch flashes to indicate you are in Save mode. One of the upper line LEDs blinks. Press one of the 6 switches (from TAP to FREEZE) to select a bank. Then one of the lower line LEDs blinks. Press one of the 6 switches (from TAP to FREEZE) to select a preset.

All the parameters and pot positions are now saved in the selected preset.

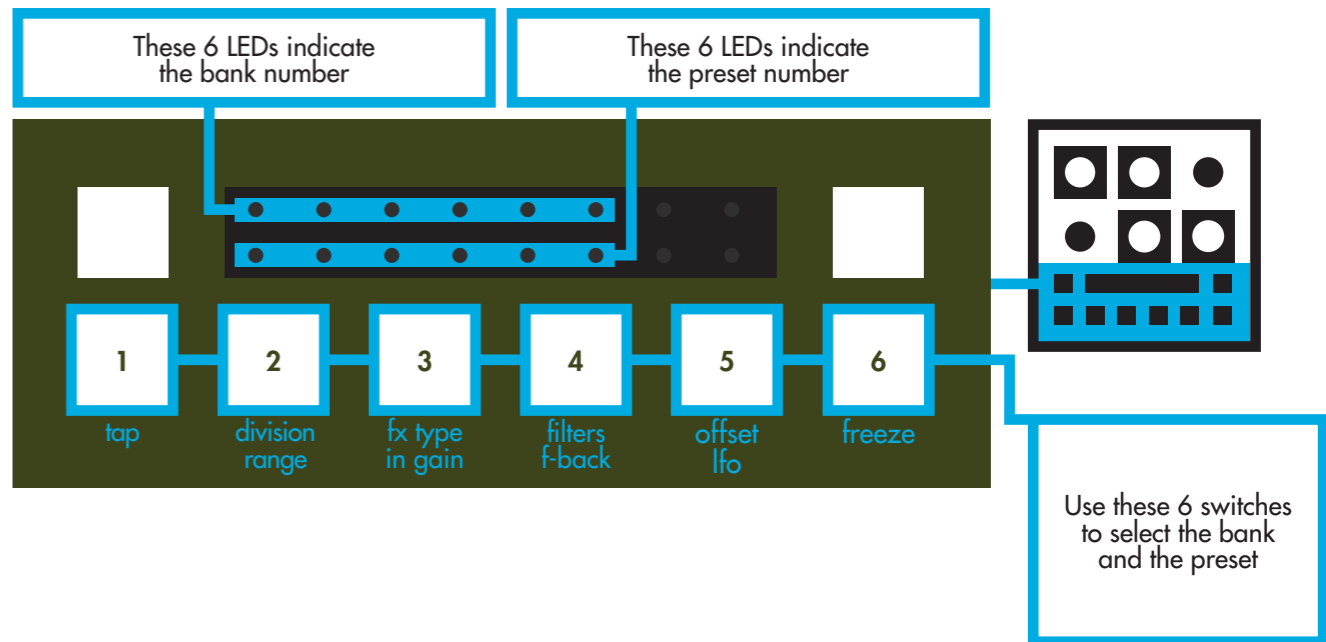

## EXIT WITHOUT LOADING OR SAVING A PRESET

If you press the PRESET switch before selecting the bank or the preset, the preset won't be loaded or saved. You can also wait 10 seconds.

## POTENTIOMETERS POSITION

Once you recall a preset, the physical position of a pot may not be the same as in the preset. To prevent a sudden jump of volume when you turn a pot, the preset value will reach the pot value with a smooth fade.

**Table 1 : Factory Presets list**

1.1 The Nymph Echo	1.2 Dark Slap	1.3 Psychotron	1.4 Faux Spring	1.5 Dust Memories	1.6 Vibrotto
2.1 I See Icy	2.2 Moving Resonator	2.3 Tunneling	2.4 Short and Sweet	2.5 Dirty Repeats	2.6 Seasickness

## FACTORY PRESETS

The first 2 banks are filled with 12 factory presets. These 12 factory presets are listed on table 1.

## MEMORY PROTECT

You can prevent overwriting your presets with the Memory Protect function. Press PRESET and FREEZE switches and hold them for at least 2 seconds. The PRESET and FREEZE switches, and one of the following LEDs will flash to indicate the current Memory Protect mode :

**Led 1.** OFF The memory is not protected.

**Led 2.** ON The memory is protected and you cannot save presets. If you attempt to save a preset, LEDs 1 to 6 and 9 to 14 will flash briefly to indicate that memory is protected.

You can now change the Memory Protect mode with the DATA pot.

To exit the Memory Protect setting, wait for 10 seconds or press the FREEZE or the PRESET switch.

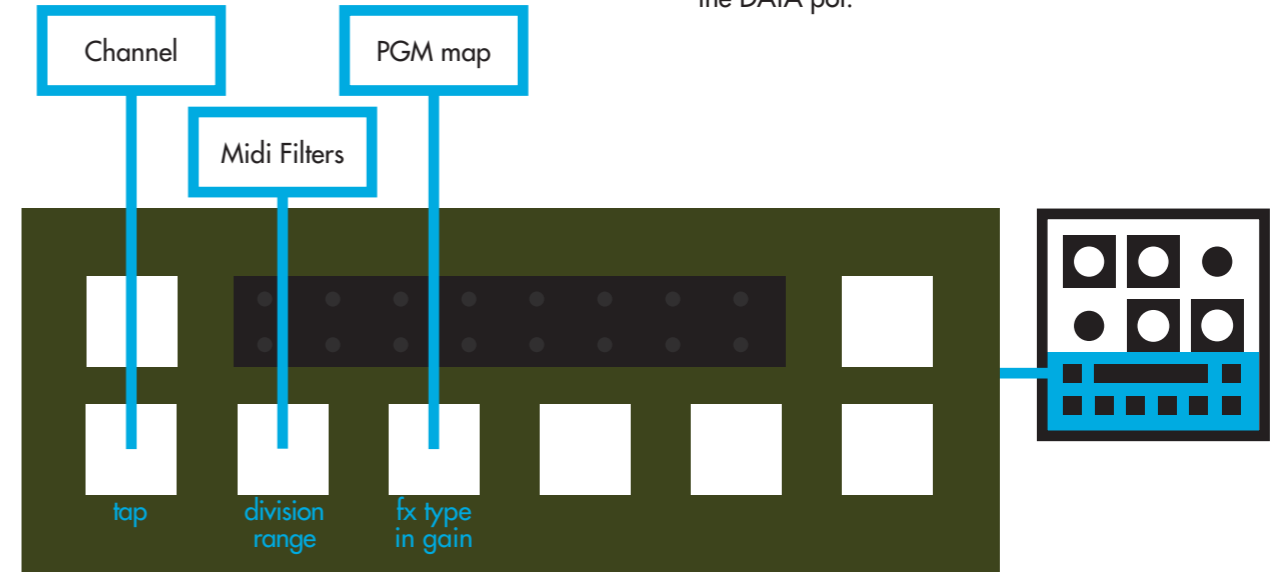

## MIDI

The MIDI settings menu gives you access to the following functions :

- MIDI Channel selection
- MIDI Filters
- Program Change map

To access the MIDI menu, press the ACTIVE switch while pressing the PRESET switch.

The TAP, DIVISION and FX TYPE keys flash. Press any of these switches to access to the corresponding sub-menu.

### 1. CHANNEL

One of the 16 LEDs will flash and display which channel is selected. You can select a MIDI channel by turning the DATA pot.

## 2. MIDI FILTERS

One of the TAP, DIVISION, FX TYPE or FILTERS switch is lit (the filter is off, BIM will accept the corresponding MIDI message) or flashing (the filter is on, BIM will ignore the corresponding MIDI message).

The 4 MIDI FILTERS are :

1. Continuous Controllers (TAP switch)
2. Beat Clock to Delay Time (DIVISION switch)
3. Beat Clock to LFO Rate (FX TYPE switch)
4. Program Change (FILTERS switch)

To activate or deactivate a filter, press the corresponding switch.

## 3. PGM CHANGE MAP

BIM has 36 presets and MIDI Program Change messages have 128 values. You can associate any BIM preset to any Program Change message number.

When the PGM Change Map sub-menu is selected, send a Program Change message from your computer, sequencer or any MIDI device. As soon as BIM receive a Program Change message, it will give you access to a preset selection menu (same as « Recall a Preset » cf page 15). The selected preset will now be associated with the previously received Program Change message.

### Reset Program Change map

If you press OFFSET and FREEZE switches simultaneously while you are in the Program Change Map sub-menu, the Program Change map will be reset (cf Table 2).

To exit the MIDI menu, press the ACTIVE or the PRESET switch.

Table 2 : Default Program Change list

Preset	PGM Chge Nr	Preset	PGM Chge Nr	Preset	PGM Chge Nr
1.1	1 - 37 - 73 - 109	3.1	13 - 49 - 85 - 121	5.1	25 - 61 - 97
1.2	2 - 38 - 74 - 110	3.2	14 - 50 - 86 - 122	5.2	26 - 62 - 98
1.3	3 - 39 - 75 - 111	3.3	15 - 51 - 87 - 123	5.3	27 - 63 - 99
1.4	4 - 40 - 76 - 112	3.4	16 - 52 - 88 - 124	5.4	28 - 64 - 100
1.5	5 - 41 - 77 - 113	3.5	17 - 53 - 89 - 125	5.5	29 - 65 - 101
1.6	6 - 42 - 78 - 114	3.6	18 - 54 - 90 - 126	5.6	30 - 66 - 102
2.1	7 - 43 - 79 - 115	4.1	19 - 55 - 91 - 127	6.1	31 - 67 - 103
2.2	8 - 44 - 80 - 116	4.2	20 - 56 - 92 - 128	6.2	32 - 68 - 104
2.3	9 - 45 - 81 - 117	4.3	21 - 57 - 93	6.3	33 - 69 - 105
2.4	10 - 46 - 82 - 118	4.4	22 - 58 - 94	6.4	34 - 70 - 106
2.5	11 - 47 - 83 - 119	4.5	23 - 59 - 95	6.5	35 - 71 - 107
2.6	12 - 48 - 84 - 120	4.6	24 - 60 - 96	6.6	36 - 72 - 108

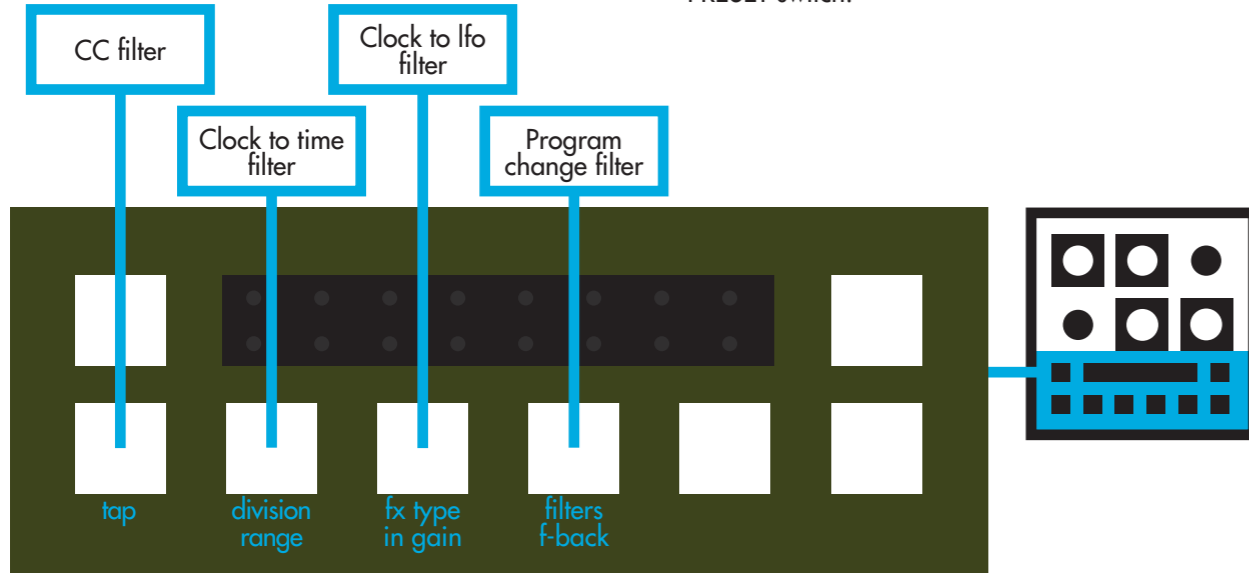

Table 3 : MIDI CC list

Param	CC
Delay	12
Feedback	13
Mix	14
LFO Rate	15
LFO Depth	16
Active	17
Division	18
Range	19
FX Type	20
In Gain	21
HPF	22
LPF	23
Feedback Filters	24
Offset	25
LFO Wave	26
LFO Range	27
Freeze	28
Freeze Reverse	29
LFO Division	30
LFO Phase Reset	31

## SPECIFICATIONS

### Inputs

Connectors : 1/4" phone jacks  
 Input type : single ended  
 Impedance : 1 MOhm  
 Max input level : +20 dBu (@1% THD+N)

### Outputs

Connectors : 1/4" phone jacks  
 Output type : single ended  
 Impedance : 100 Ohm  
 Max output level : +20 dBu

### Dry signal specifications

THD+N : 0.007 %  
 (20Hz - 20kHz, 0dBu)  
 Frequency response : - 0.16 dBu @ 20Hz  
 - 0.23 dBu @ 20kHz  
 Dynamic range : 106 dB

### Wet signal specifications

THD : 0.089 %  
 (@1kHz, 0dBu)  
 Frequency response : - 0.48 dBu @ 20Hz  
 - 3.00 dBu @ 15kHz  
 Dynamic range : 93 dB

### General

Dimensions : 145 x 145 x 65 mm  
 Weight : 762 g

### Power supply

Input : 100 to 240 VAC,  
 50 to 60 Hz, 0.6 Amp  
 Output : +15 VDC, 1 Amp  
 Dimensions : 74 x 43 x 35 mm  
 Weight : 165 g

**DUE TO CONTINUOUS PRODUCT IMPROVEMENT,  
 THESE SPECIFICATIONS ARE SUBJECT TO CHANGE WITHOUT NOTICE.**

### Reset

If you want to restore the default System settings, power up BIM while pressing the ACTIVE and TAP switches.

The ACTIVE and TAP switches are lit and the 16 LEDs will display a little animation for 3 seconds.

If you want to restore the 12 Factory Presets, power up BIM while pressing the PRESET and FREEZE switches.

The PRESET and FREEZE switches are lit and the 16 LEDs will display a little animation for 10 seconds.

## SHORTCURTS SUMMARY

### Active mode

Press ACTIVE for 2 seconds :  
LED 1 : Relay  
LED 2 : Spillover  
LED 3 : Aux

### Midi

Press ACTIVE + PRESET :  
TAP : Channel  
DIVISION : MIDI Filters  
FX TYPE : Pgm Chge Map

### Memory protect

Press PRESET + FREEZE  
for 2 seconds :  
LED 1 : OFF  
LED 2 : ON

### Freeze.

Press OFFSET and  
FREEZE for 2 seconds :  
LED 1 : Latch  
LED 2 : Reverse Latch  
LED 3 : Momentary  
LED 4 : Reverse  
Momentary

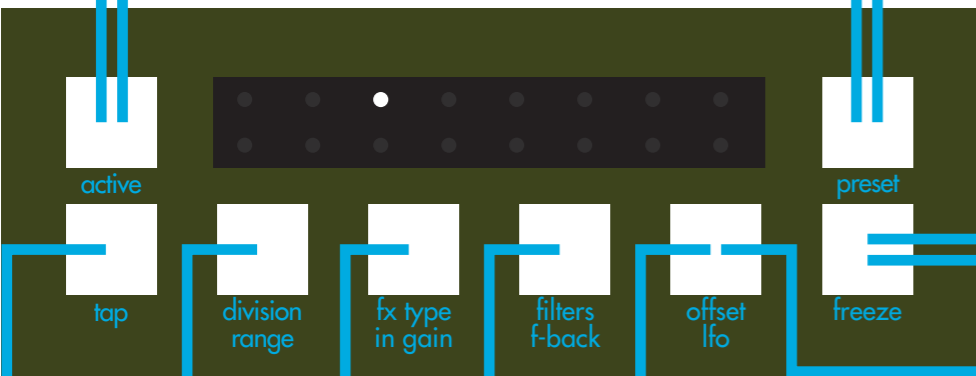

### Tap destination

Press TAP  
for 2 seconds :  
LED 1 : TAP to Delay  
LED 2 : TAP to LFO Rate  
LED 3 : TAP to Delay and  
LFO Rate

### Local

Press FX TYPE  
for 2 seconds :  
LED 1 : LOCAL  
LED 2 : PRESET

### Feedback limiter

Press FILTERS  
for 2 seconds :  
LED 1 : ON  
LED 2 : OFF

### LFO divisions

Press OFFSET  
for 2 seconds :  
LED 1 : Sixteenth note  
LED 2 : Eighth note  
LED 3 : Quarter note  
LED 4 : Half note  
LED 5 : Whole note

### Display mode

Press DIVISION for 2 seconds :  
LED 1 : OFF  
LED 2 : VU-METER  
LED 3 : LFO RATE  
LED 4 : PRESET

ARTWORK : H5 (P. MANAS & L. HOUPLAIN).  
ILLUSTRATIONS : PIERRE MANAS.

BIM - USER MANUAL OTO MACHINES SARL  
27 BOULEVARD SAINT MARTIN, 75003 PARIS FRANCE  
+33 (0)1 75 50 61 04  
www.otomachines.com

Copyright © 2015 OTO Machines SARL. All rights reserved.

No part of this manual may be reproduced in any form without the written permission of OTO Machine SARL.  
Product features, specifications, availability and informations in this manual are subject to change without notice.



Tested to Comply with FCC Standards for office use. This device complies with Part 15 of the FCC Rules.

Operation is subject to the following two conditions :

- (1) This device may not cause harmful interference and
- (2) this device must accept any interference received, including interference that may cause undesired operation.

